

2019 national curriculum tests

Key stage 2

Mathematics

Paper 2: reasoning

First name						
Middle name						
Last name						
Date of birth	Day		Month		Year	
School name						
DfE number						



[BLANK PAGE]

Please do not write on this page.



Instructions

You **must not** use a calculator to answer any questions in this test.

Questions and answers

You have **40 minutes** to complete this test.

Follow the instructions for each question.

Work as quickly and as carefully as you can.

If you need to do working out, you can use the space around the question.

Do not write over any barcodes.

Some questions have a method box like this:

For these questions, you may get a mark for showing your method.

If you cannot do a question, **go on to the next one.**

You can come back to it later, if you have time.

If you finish before the end, **go back and check your work.**

Marks

The number under each line at the side of the page tells you the number of marks available for each question.



1

In this grid, there are four multiplications.

Write the **three** missing numbers.

4	×	8	=	
×		×		
3	×		=	21
=		=		
		56		

1 mark

2

What number is 1,000 **less** than 9,072?

1 mark



3

Order the numbers starting with the **largest**.
Match each number with its order.

1,009,909

1st

largest

1,023,065

2nd

1,009,099

3rd

1,230,650

4th

smallest

1 mark



4

Here is a shaded shape on a square grid.

Reflect the shape in the mirror line.

Use a ruler.

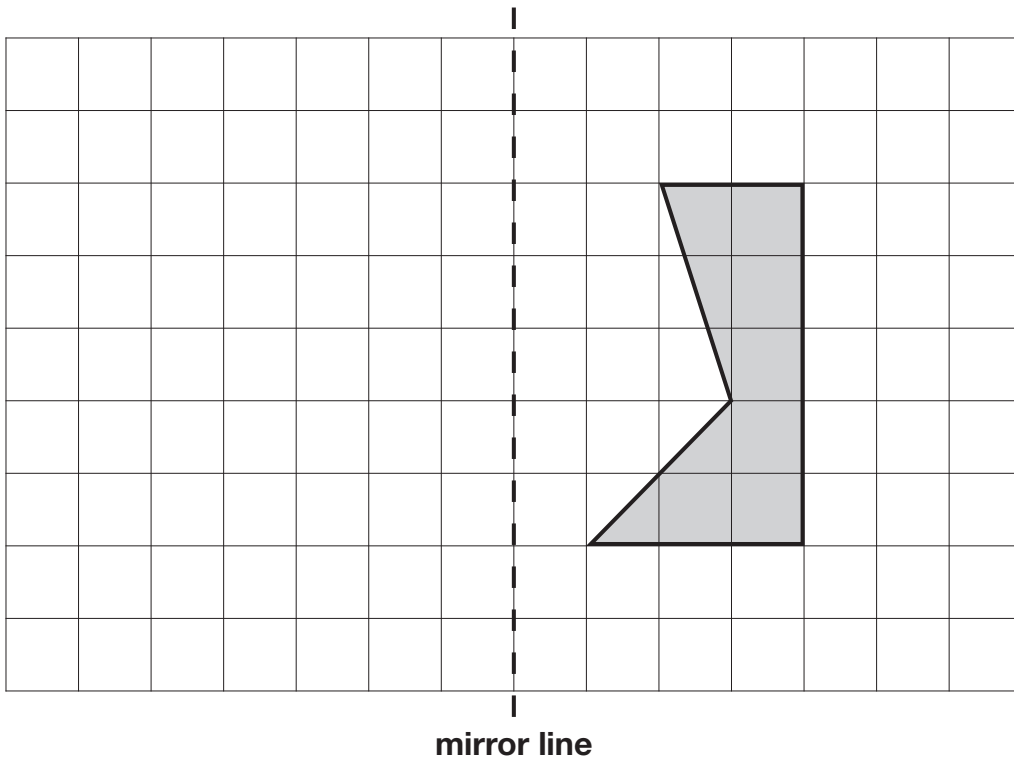

1 mark



5

The numbers in this sequence **increase** by 45 each time.

Write the missing numbers.

<input type="text"/>	155	200	245	<input type="text"/>	<input type="text"/>
----------------------	-----	-----	-----	----------------------	----------------------

2 marks

6

Write the missing number to make this **division** correct.

$$0.3 \div \boxed{} = 0.03$$

1 mark



H 0 0 0 7 0 A 0 7 2 4

7

Jack pours some dark paint into a container.

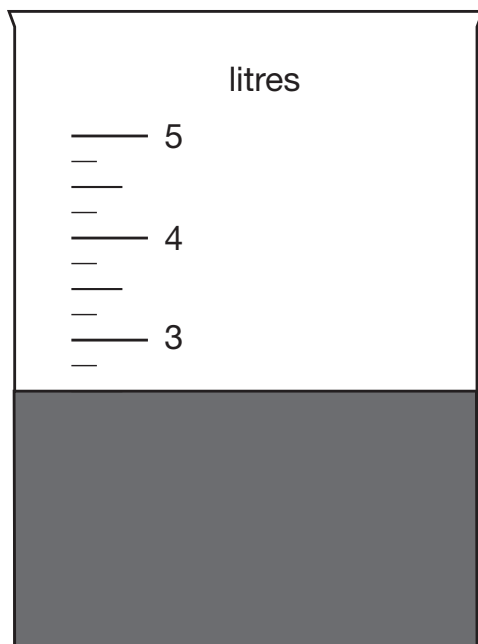

In litres, how much paint is in the container?

litres

1 mark



8

In this sequence, the rule to get the next number is

Multiply by 2, and then add 3

Write the missing numbers.

	25	53	
--	----	----	--

1 mark

1 mark



9

Jack chose a number.

He multiplied the number by 7

Then he added 85

His answer was 953

What number did Jack choose?

Show
your
method

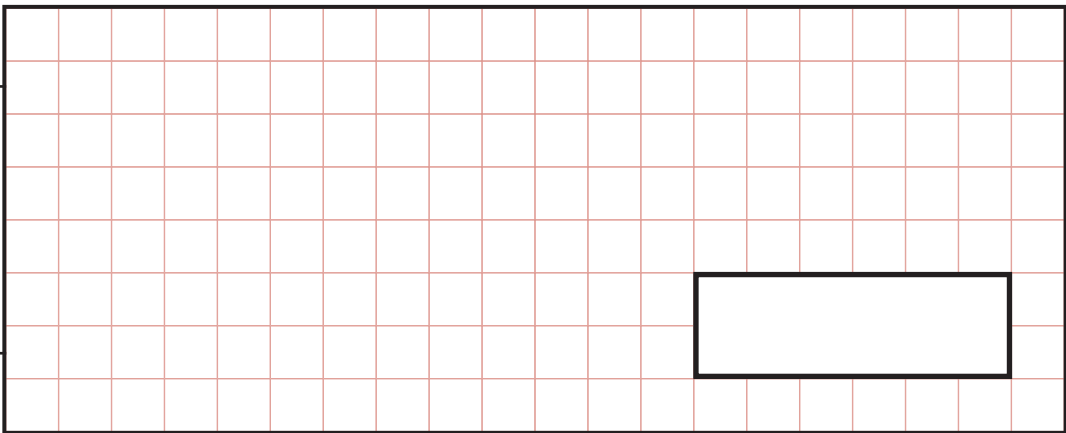

2 marks



10

A theme park sells tickets online.

Each ticket costs £24

There is a £3 charge for buying tickets.

Which of these shows how to calculate the total cost, in pounds?

Tick **one**.

number of tickets $\times 3 + 24$

number of tickets $\times 24 + 3$

number of tickets $+ 3 \times 24$

number of tickets $+ 24 \times 3$

1 mark



11

Amina is shopping.

She says,



I would like to buy **one-quarter** of a kilogram of cheese.

Write one-quarter on the scales as a decimal.

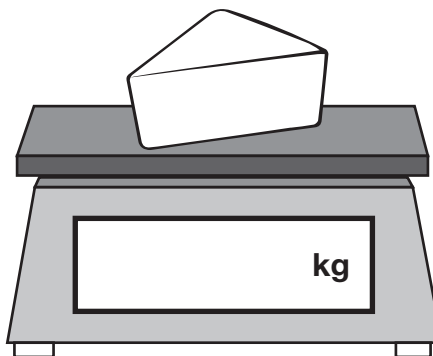

1 mark

The cheese costs £1.35

Amina pays with a £2 coin.

How much change should Amina get?

1 mark



12

Here are three symbols.

< > =

Write one symbol in each box to make the statements correct.

$$\frac{7}{10} \quad \square \quad 0.07$$

$$\frac{23}{1000} \quad \square \quad 0.23$$

1 mark

13

Here is a sketch of a triangle.

It is not drawn to scale.

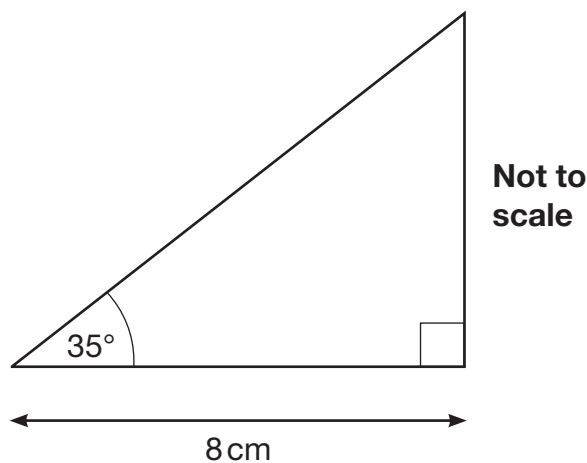

Draw the full-size triangle **accurately** below.

Use an angle measurer (protractor) and a ruler.

One line has been drawn for you.

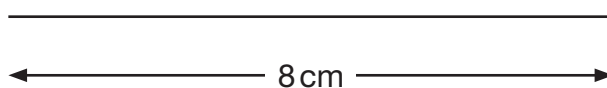

2 marks



14

Complete the table.

	Round 39,476
to the nearest 10,000	
to the nearest 1,000	
to the nearest 100	

2 marks

15

Amina asked 60 children to choose their favourite flavour of jelly.

These were her results.

Flavour	Number of children
Raspberry	12
Lemon	8
Orange	15
Blackcurrant	25
Total	60

What **percentage** of the 60 children chose orange?
 %

1 mark



16

Write the missing number.

$$6 + 2 \times 2 - \square = 6$$

1 mark

17

These two shapes have the **same** perimeter.

regular hexagon

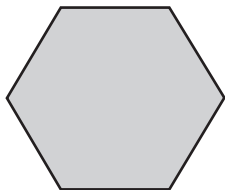

square



Not actual size

The length of each side of the **hexagon** is **8** centimetres.

Calculate the **area** of the **square**.

Show your method

2 marks



18Circle the **prime** number.

95

89

87

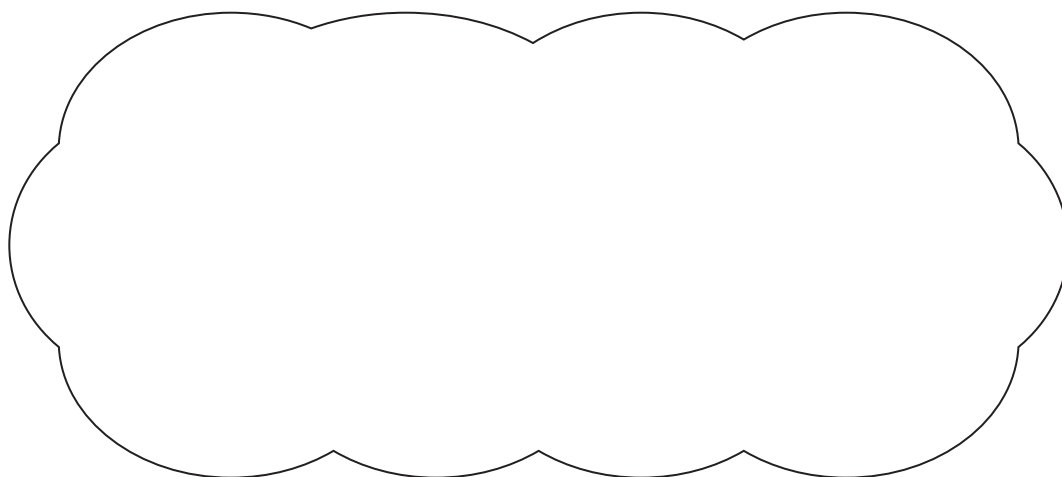
Explain how you know the other numbers are **not** prime.1 mark

19

A machine pours 250 millilitres of juice every 4 seconds.

How many **litres** of juice does the machine pour every **minute**?

Show
your
method

A large grid for showing the method. A small box labeled "litres" is placed on the grid.

2 marks



20

Tick the fractions that are **equal** to 20%.

$$\frac{1}{20} \quad \square$$

$$\frac{20}{40} \quad \square$$

$$\frac{1}{5} \quad \square$$

$$\frac{3}{15} \quad \square$$

$$\frac{2}{100} \quad \square$$

2 marks

21

Adam has this rectangular piece of card. It is marked with grid lines.

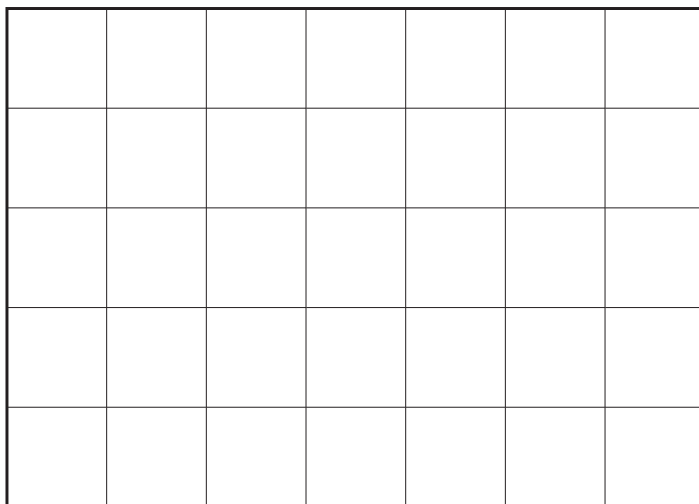

1 mark

Adam makes two straight cuts along the grid lines.

The two cuts divide the rectangle into 3 shapes:

- 2 squares of **different** size, and
- 1 rectangle.

Using the grid lines, draw **two** lines that show where Adam could have made his cuts.

Use a ruler.



22

This graph shows the maximum temperature for five days.

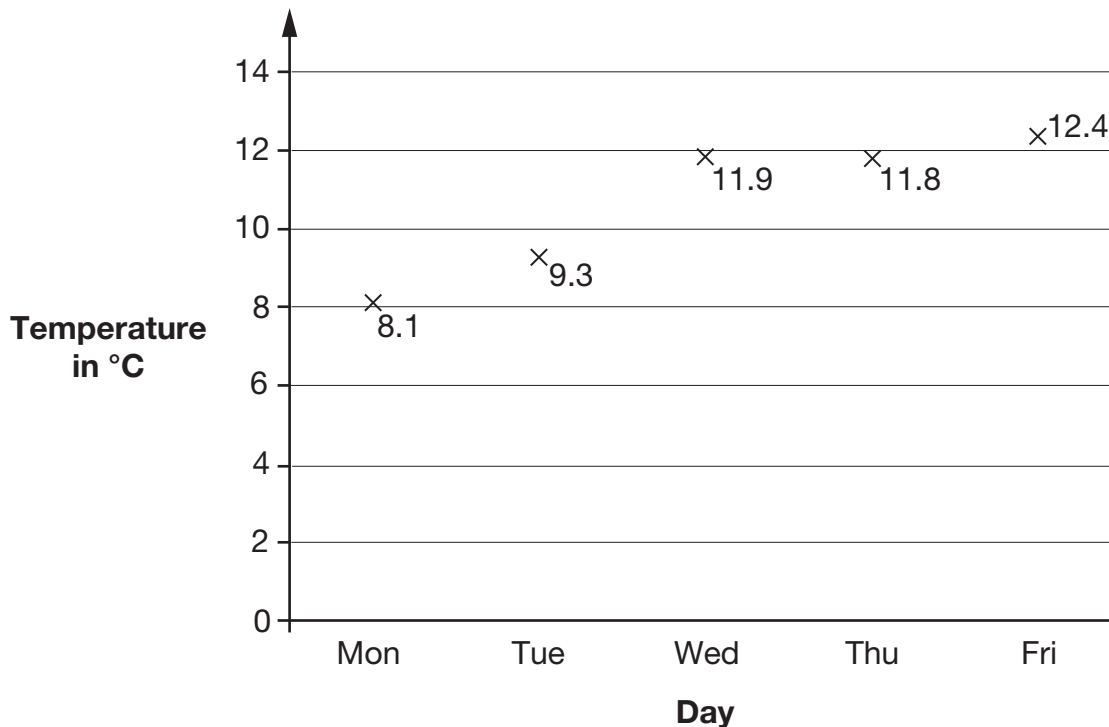

For what fraction of the five days was the maximum temperature below 10 °C?

1 mark

What was the **mean** maximum temperature, to one decimal place?

Show your method

°C

2 marks



23

Amina made this cuboid using centimetre cubes.

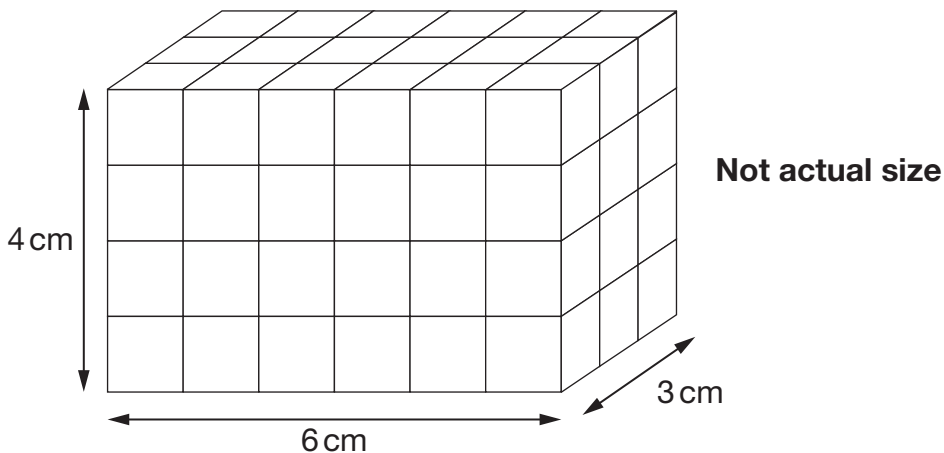

Stefan makes a cuboid that is 5 cm longer, 5 cm taller and 5 cm wider than Amina's cuboid.

What is the **difference** between the number of cubes in Amina's and Stefan's cuboids?

Show
your
method

cubes

2 marks



[END OF TEST]

Please do not write on this page.





Standards
& Testing
Agency

2019 key stage 2 mathematics

Paper 2: reasoning

Print version product code: STA/19/8217/p ISBN: 978-1-78957-012-0

Electronic PDF version product code: STA/19/8217/e ISBN: 978-1-78957-032-8

For more copies

Additional copies of this book are not available during the test window.

They can be downloaded afterwards from

<https://www.gov.uk/government/collections/national-curriculum-assessments-practice-materials>.

© Crown copyright 2019

Re-use of Crown copyright in test materials

Subject to the exceptions listed below, the test materials on this website are Crown copyright and you may re-use them (not including logos) free of charge in any format or medium in accordance with the terms of the Open Government Licence v3.0 which can be found on the National Archives website and accessed via the following link: www.nationalarchives.gov.uk/doc/open-government-licence. When you use this information under the Open Government Licence v3.0, you should include the following attribution: 'Contains material developed by the Standards and Testing Agency for 2019 national curriculum assessments and licensed under Open Government Licence v3.0' and where possible provide a link to the licence.



Exceptions – third-party copyright content in test materials

You must obtain permission from the relevant copyright owners, as listed in the '2019 key stage 2 tests copyright report', for re-use of any third-party copyright content which we have identified in the test materials, as listed below. Alternatively, you should remove the unlicensed third-party copyright content and/or replace it with appropriately licensed material.

Third-party content

These materials contain no third-party copyright content.

If you have any queries regarding these test materials, contact the national curriculum assessments helpline on 0300 303 3013 or email assessments@education.gov.uk.

